



Technical comercial data ref.

Serie MASTER NOVA

CAPO011604 30-11-22

TECHNICAL DATA:

Material: Polypropylene copolymer of first quality, suitable for contact with food according to current regulations.

Colours: White standard. Consult for other colours.

Useful Volume: 0.8 litres
Volume to the edge: 0.9 litres

Weight of the bucket: 47 g. approx.
Weight of the lid: 15 g. approx.
Total Weight: 62 g. approx.

Design surface photographic finish: 75 x 335 mm (height x perimeter)



MEASUREMENTS:

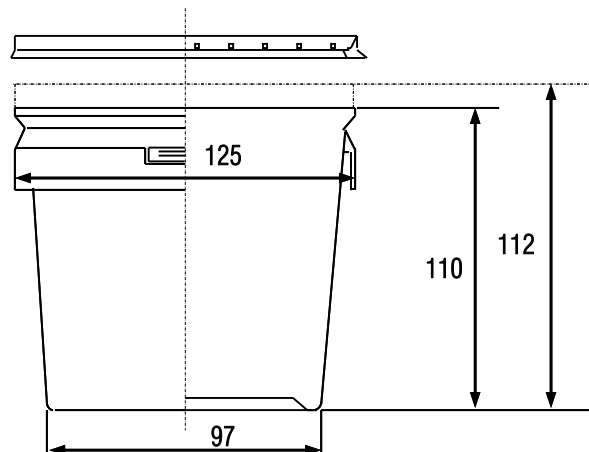

Measurements in millimetres

GROUPING OF TRANSPORT:

Tubs: 6500 tubs per pallet
250 tubs per box, this serves as a packaging of transportation

Box dimension: 370 x 250 x 895

Pallet dimensions: 1250 x 1000 x 2000 (see drawing)

Lids: 500 lids per box, this serves as a packaging of transportation

Box dimension: 210 x 490 x 630

